

This article is provided as a reference for use as is. If you have further questions or comments about this article please contact us at <http://www.calservice.net> - [Click Here](#) to go to our Reference Materials.

PRESSURE TRANSDUCERS INSTALLATION AND USE

INTRODUCTION

Common problems or questions concerning the use of pressure transducers are:

1. Transducer outputs and their wiring configurations;
2. Wiring one transducer to multiple readouts, recorders, computers, etc.;
3. Wiring multiple transducers to one readout, recorder, computer, etc.;
4. Using a milliamp signal with voltage input instrumentation;
5. Determining how many transducers can be excited from one power supply.

Each of these problems, or questions are discussed in detail in the following article.

TRANSDUCER OUTPUTS AND THEIR WIRING CONFIGURATIONS

OMEGA® transducers have three main types of electrical outputs; millivolts (mV), volts (V), and current (mA). It is important for the user to know which output suits his application to ensure proper selection of a transducer. The following will describe the advantages, disadvantages, and

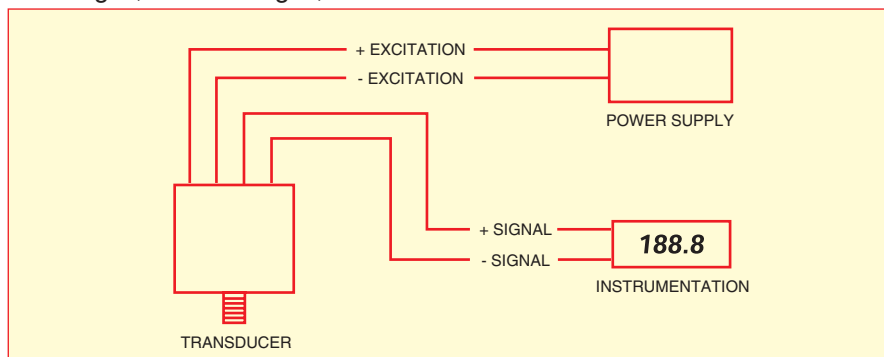

Figure 1: Typical wiring configuration for millivolt output transducer

wiring for millivolt, volt and current output transducers.

Transducers with a millivolt output are generally used in laboratory applications. They are low cost, small in size, and require a regulated power supply. Remembering that the millivolt signal is very low level, it is limited to short distances (up to 200 feet is usually considered the limit) and is very prone to stray electrical interference from other nearby electrical signals (other

instrumentation, high ac voltage lines, etc.). Typical wiring configurations are shown in Figure 1.

Transducers with an amplified voltage output are generally used in a light industrial environment and computer interface systems, where a higher level dc signal is required. Due to the built-in signal conditioning, they are higher cost and larger in size than the millivolt output transducers. Amplified voltage signals can travel up to medium distances and are much better in

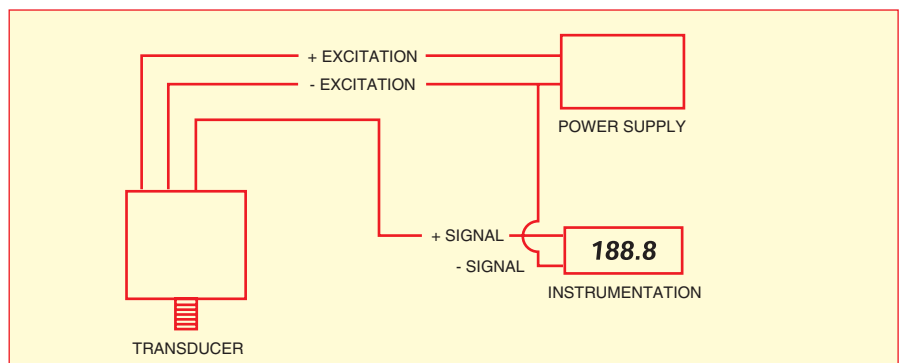

Figure 2: Typical wiring configuration for voltage output transducer (-excitation and -signal are common)

their immunity to stray electrical interference than the millivolt signal. Typical wiring configurations are shown in Figure 2.

Transducers with a current output are generally used in heavy industrial environments, and are the most common type used in process control. Transducers with a current output are generally called transmitters. The difference between a transducer and a transmitter is a commonly

asked question.

A transducer produces millivolts, amplified voltage, or current output. A transmitter produces current output only. Again, due to the built-in signal conditioning, the transmitters are higher cost and larger in size than the millivolt output transducers. Unlike the millivolt and voltage output transducers, a current signal is immune to any stray electrical interference, a valuable asset in the factory. A current signal also can be transmitted long distances. Typical

wiring configurations are shown in Figure 3.

WIRING ONE TRANSDUCER TO MULTIPLE READOUTS, RECORDERS, COMPUTERS, ETC.

One of the great advantages of a current signal is the simplicity in setting up a multi-instrument system. Long distance transmission from instrument to instrument without electrical interference make multi-instrument systems easy. For example, a material test center may have one control room for all the different test labs, enabling operation from one central location. Instrument calibration and troubleshooting are simple in a multi-instrument current loop. The only limitation for the number of instruments is the amount of voltage from the power supply driving the current loop. The minimum voltage required is determined by Ohms law, $V=IR$ (voltage equals current times resistance). This is shown and explained in Figure 4.

This article is provided as a reference for use as is. If you have further questions or comments about this article please contact us at <http://www.calservice.net> - [Click Here](#) to go to our Reference Materials.

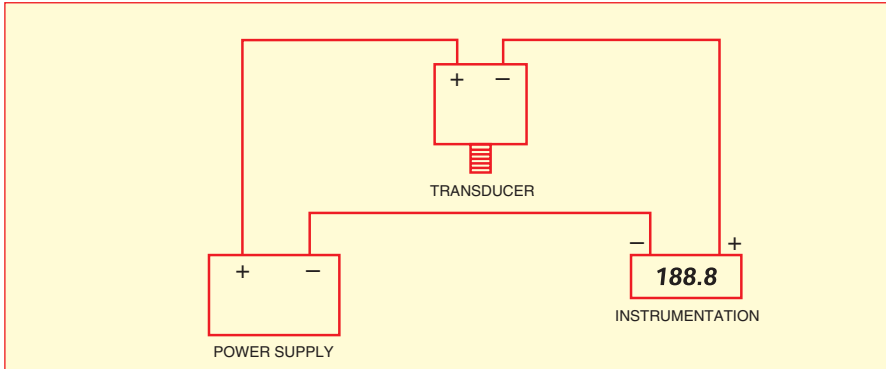

Figure 3: Typical wiring configuration for current output transducer

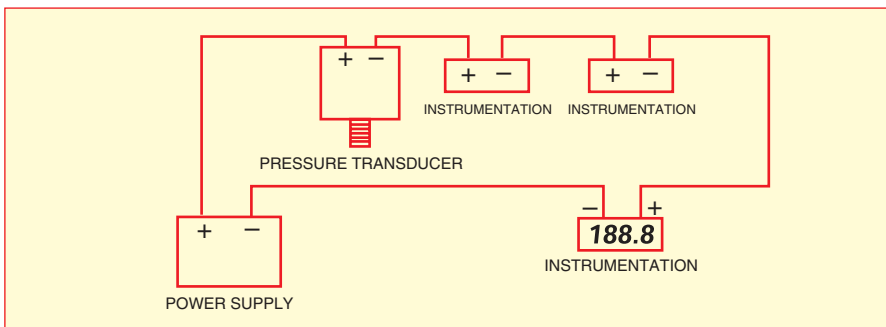

Figure 4: Multi-instrument 4-20 mA current loop (panel meters, chart recorder, computers, etc.)

$$\text{Minimum voltage req'd} = (0.20 \text{ Amps})(R_{\text{LINE}} + R_{\text{LOAD}}) + V_s_{\text{TRANSDUCER}}$$

WHERE:

R_{LINE} = resistance due to wire

R_{LOAD} = combined instrumentation resistances

$V_s_{\text{TRANSDUCER}}$ = minimum supply voltage for transducer

For example, let's assume you have the following:

1. Pressure transmitter (4-20 mA) with 12-30 Vdc supply voltage;
 2. Panel meter with a 10 ohm input impedance;
 3. Recorder with a 25 ohm input impedance;
 4. Computer with a 200 ohm input impedance;
 5. Lead wire resistance of 5 ohms.
- Minimum voltage required = $(.020)(5 + 10 + 25 + 200) + 12 = 16.8$ volts
 24 volts is the most common power supply in a 4-20 mA current loop.
 Wiring a voltage or millivolt signal to multiple instruments also can be done, but is not as easy and does not have the calibration and troubleshooting advantages inherent

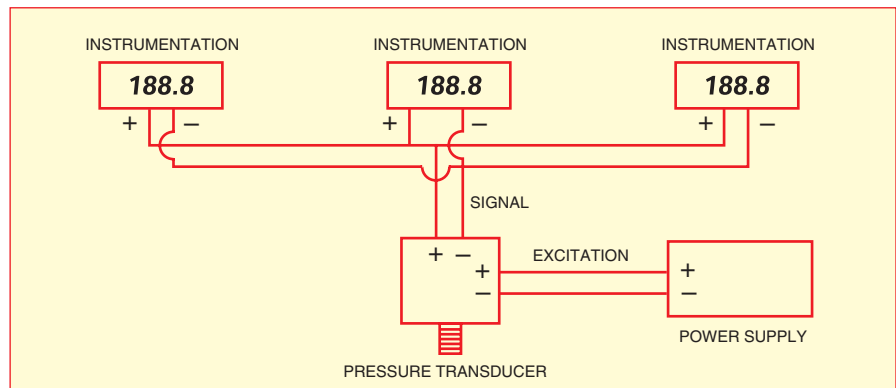

Figure 5: Multiple instruments wired in parallel to a voltage output transducer

in a current loop system. The voltage or millivolt signal can be wired in parallel to multiple instruments as shown in Figure 5. This method assumes a very high input impedance in the instruments being wired. If this is not the case, an analog output can be used instead to retransmit the signal.

WIRING MULTIPLE TRANSDUCERS TO ONE READOUT, RECORDER, COMPUTER, ETC.

In measuring multiple pressures, it is a common mistake trying to use multiple transducers, a switching device, and just one panel meter, thus saving money on multiple panel meters (or any other instrumentation). The problem is that each transducer has a unique zero point and the readout only has one zero screw. The net result is that the total accuracy increases to about 3%, even though each sensor is 0.5% accurate. In most cases, this larger error is intolerable.

The correct method of using multiple transducers with one readout device is to use transducers that have built-in zero and span adjustments screws, the same output (voltage or current), and the same pressure range. Each transducer is adjusted by applying a known pressure, so that they all have identical outputs. When they all have identical outputs, the meter is scaled and a switch can be used.

Another solution to using multiple transducers with one readout is to use a scanner instead of a meter and

a switch. There are many types of scanners. The type of scanner that works with multiple pressure transducers must have independent scaling on each channel.

Some scanners, besides having independent scaling on each channel, also offer independent current, voltage, or millivolt inputs to each channel. These types of scanners enable you to use transducers with different outputs as well as different pressure ranges with the same instrument.

This article is provided as a reference for use as is. If you have further questions or comments about this article please contact us at <http://www.calservice.net> - [Click Here](#) to go to our Reference Materials.

PRESSURE TRANSDUCERS (Continued)

USING A MILLIAMP SIGNAL WITH VOLTAGE INPUT INSTRUMENTATION

Most instrumentation is set up to receive voltage. A commonly asked question is how to use a current signal with instrumentation set up for voltage. This is simply done by installing a resistor across the input terminals of the instrumentation. The value of the resistor is determined by Ohms law ($V = IR$). For example, installing a 500 ohm resistor will convert 20 mA to 10 volts ($V = IR = .020 \times 500$). This is shown in Figure 7. The only other consideration is the zero offset. Since most current loops have a low end of 4 mA, there will be a zero offset. Using the same value resistor as above, 4 mA will convert to 2 volts.

$$R = \frac{V}{I}$$

Where: R = Size of Resistor
V = Desired Voltage
I = Current

Example:

To Convert 4-20 mA into 2-10 V

$$R = \frac{V}{I} = \frac{10}{.02} = 500 \text{ Ohms}$$

A 500 Ohm Resistor Would be Installed Across the (+) and (-) Terminals on the Instrumentation

DETERMINING HOW MANY TRANSDUCERS CAN BE EXCITED FROM ONE POWER SUPPLY

Multiple transducers can be excited from one power supply. The number

of transducers that can be used is simply determined by the current draw of each transducer and the current capacity of the supply source. The sum of the current draw of the transducers can not exceed the total current capacity of the supply. For example, if you have 50 transducers drawing 13 milliamps, you will need a power supply having at least 650 milliamps (50×13). There is also nothing wrong with powering just one transducer with a power supply having high current capacity.

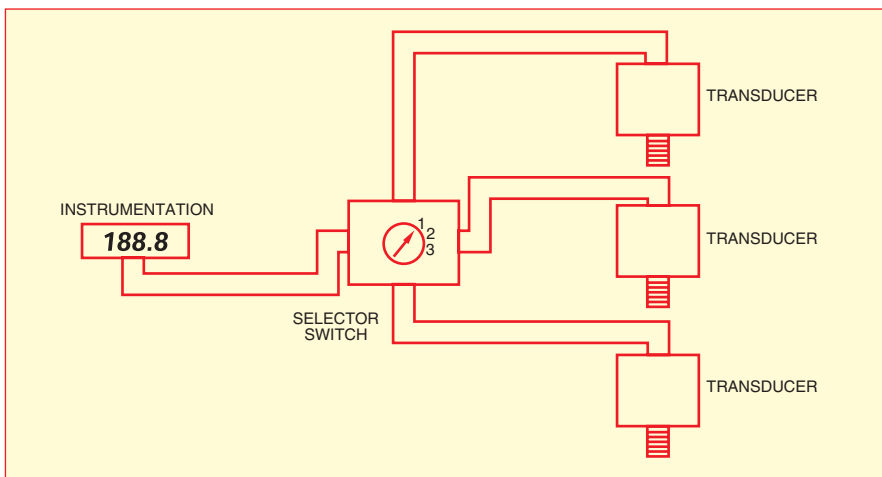

Figure 6: Multiple transducers wired to one meter and one switch (transducers with built-in zero & span adjustments, same outputs & same pressure ranges)

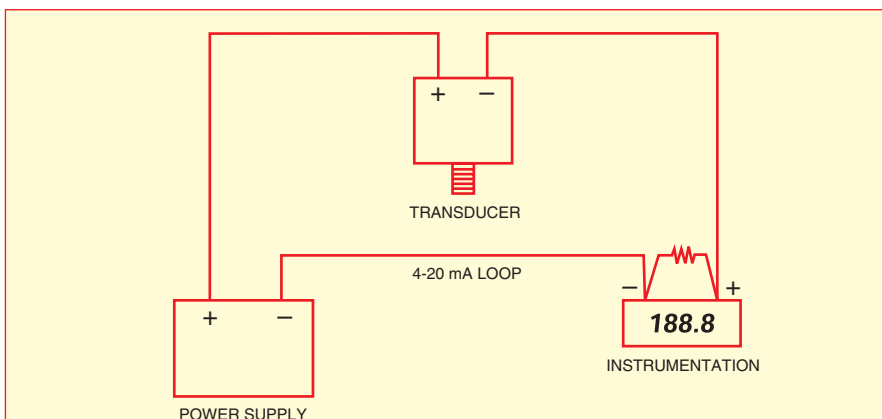

Figure 7: Converting current into voltage for instrumentation set up for voltage

HANDLING, LOCATING AND INSTALLING TRANSDUCERS

- A. Diaphragm** - Do not press or touch the diaphragm as you may damage or alter its calibration, particularly on low pressure range models.
- B. Fittings and Hardware** - Use appropriate pressure rated fittings and hardware. Make sure you have the correct thread type and size fitting. Use pressure limiters, capacity chambers, snubbers, etc., if needed.
- C. Operate at Ambient Temperatures** - Locate the transducer where it can be readily inspected and serviced. Ambient temperature should be within the transducer specifications. The temperature coefficient effects on the overall accuracy of the transducer can be minimized the closer the ambient temperature is to 25°C. Avoid locations with excessive vibration.
- D. Installation** - Installation should be made only by qualified personnel familiar with safety practices and knowledgeable with all industry accepted standard relating to pressure systems. Transducer calibration and/or zero may shift if it is over-torqued when installing. Check for a zero shift after installing. When installing transducers, refer to standard industry torque data for thread size and material type.

WATERHAMMER

A COMPLEX PHENOMENON WITH A SIMPLE SOLUTION

Waterhammer is an impact load that is the most misunderstood force known to pressure transducers today. A waterhammer is created by stopping and/or starting a liquid flow suddenly. The results of a waterhammer or impulse load are devastating to a pressure sensor. The impulse load occurs suddenly, in the millisecond time frame, but the effects of it last a life time. Waterhammers occur in almost all pressure systems and usually can not be stopped without extensive time, energy and studies.

A common example of a waterhammer occurs in most homes everyday. Simply turning off a shower quickly sends a loud thud through the house; this is a perfect example of a waterhammer. Dishwashers and washing machines make these same sounds, because inside them small solenoid valves are being opened and closed quickly, producing this pulse noise. The key phrase in the examples above was turning on or off the water "quickly" verses turning it off slowly. In the shower example, if you turn the water off slowly, the waterhammer will not occur. Common industrial hardware like relief valves, solenoid valves, valves in general, centrifugal pumps, positive displacement pumps, and regulators can and will cause heavy hammer effects. A simple solution to this devastating effect is to protect each sensor with a pressure snubber. Snubbers are low ticket items that will insure that this hammer effect will not render your costly sensor useless. All pressure sensors should utilize snubbers for all installations.

The hammer occurs because an entire train of water is being stopped so fast that the end of the train hits up against the front end and sends shock waves through the pipe. This is similar to a real train, instead of slowing to a stop, it hits into a mountain side. The back of the train continues forward even though the front can not go anywhere. Since the water flow is restricted inside the pipe, a shock wave of incompressible water travels back down the pipe deflecting everything in its path. An unprotected transducer in the path of this

monstrous wake is without question, going to sustain heavy damage.

To understand the damage caused by the waterhammer forces, it is necessary to understand the principles behind the sensor. Most pressure sensors utilize a rigid diaphragm as the primary sensing element. The diaphragm deflects due to the pressure, and its deflection is transformed to an electrical output via various methods. The key component is the rigid diaphragm. The rigid diaphragm deflects only on the order of a thousandth of an inch. With a large wake of fluid hitting the sensor, it is no wonder the diaphragm is bent beyond its elastic limit and permanent damage is done. Remember that a snubber eliminates this effect and therefore should always be installed on every pressure system.

"The results of a waterhammer or impulse load are devastating to a pressure sensor."

Snubbers are chosen by the media that they will be used on such as liquids, gases or dense liquids like motor oils, and their physical mounting fittings. Snubbers only let so much fluid pass through per unit time, eliminating the surge from hitting the diaphragm. Liquids possess a large hammer effect because they are incompressible, but gases can also possess a hammer effect large enough to render a sensor useless. A practical analogy to a snubber is a sponge in the drain of a sink. The sponge ensures that the sink empties slowly, instead of all at one. A lot of common questions are asked about hammer effects; the following are just a few.

WILL A SNUBBER EFFECT THE RESPONSE TIME OF MY PRESSURE TRANSDUCER?

In most cases, the transducer is connected to a meter or a recorder that updates at 2 to 3 times a second; therefore a snubber will not effect it at all.

WHAT ARE THE SYMPTOMS THAT MY SENSOR HAS BEEN DAMAGED BY A FLUID HAMMER?

Most sensors will exhibit a higher than normal output at zero pressure (a zero shift). This occurs because the diaphragm can not return to zero. In severe cases no output occurs or the output does not change with an increase in pressure.

IF MY SENSOR HAS A LARGE ZERO OFFSET CAUSED BY THIS HAMMER EFFECT CAN IT BE REPAIRED?

Most sensors are non-repairable. The diaphragm is the main building block of the sensor. When building a sensor the diaphragm is first built and then all the other components are chosen to achieve the rated specification. When a diaphragm bends beyond its elastic limit, it can not be bent back to original shape or replaced because of the unique components associated with the original diaphragm. If a diaphragm does have a slight zero shift, less than 10%, it probably is still linear and can be used. Before reinstalling it in the system, please acquire a snubber or the hammer effect will occur again and possibly damage the unit further.

WILL A SNUBBER STOP AN OVERPRESSURE?

Snubbers stop spikes only, they do not perform miracles. An overpressure will not be stopped by a snubber. A spike lasts only on the order of milliseconds; any overpressure for more than that time will damage the sensor.

HOW IS A SNUBBER INSTALLED IN A PRESSURE SYSTEM?

The snubber would screw on to the front end of the transducer and then thread into the piping system. The snubber is located between the piping under pressure and the pressure transducer.

The following brief equations summarize the hammer effect and is followed by an example of waterhammers destructive forces.

WATERHAMMER (Continued)

The following equation determines the maximum pressure change that occurs during a fluid hammer. The equation assumes that the piping is inelastic.

$$\Delta P = \frac{\rho c \Delta v}{g}$$

where

$$c \text{ for liquids} = \left(\frac{Eg}{\rho} \right)^{\frac{1}{2}}$$

$$c \text{ for gases} = (KgRT)^{\frac{1}{2}}$$

where

ΔP is the change in pressure resulting from the fluid hammer (pounds per square foot)

ρ is the fluid density (pound mass per cubic foot)

c is the speed of sound in the fluid (feet per second)

Δv is the change in velocity of the fluid (feet per second)

g is the gravitational constant (32.2 feet per second per second)

E is the bulk modulus of the fluid media (listed in PSI but must be converted to PSF)

k is the ratio of specific heats ($k = 1.4$ for air)

R is the specific gas constant (foot pounds per pound mass per degree Rankine)

T is the absolute temperature in Rankine

Example of waterhammer occurring in typical house piping. Assuming you have one inch water piping, how much of a change in pressure will be created from a waterhammer?

Assume that the water is flowing in 10 gallons per minute and the temperature is about room temperature (70°F). A 1 inch schedule 40 pipe has an internal area equal to 0.00600 ft².

Fluid velocity $V = Q/A = 10 \text{ gpm} / (1/448.83 \text{ gpm/cfs}) / 0.006 \text{ ft}^2 = 3.71 \text{ ft/sec}$.

Where Q is the flow rate, and A is the internal area in the pipe.

$$c = \left(\frac{Eg}{\rho} \right)^{\frac{1}{2}} = \left[\frac{(320 \times 10^3 \text{ lbs/in}^2)(144 \text{ in}^2/\text{ft}^2)(32.2 \text{ ft/sec}^2)}{62.3 \text{ lbs/ft}^3} \right]^{\frac{1}{2}} = 4880 \text{ ft/sec}$$

$$\Delta P = \frac{\rho c \Delta v}{g} = \frac{(62.3 \text{ lb/ft}^3)(4880 \text{ ft/sec})(3.71 \text{ ft/sec})}{32.2 \text{ ft/sec}^2} = \frac{3502g \text{ lbs/ft}^2}{32.2 \text{ ft/sec}^2} = 243 \text{ lbs/in}^2$$

In this example, a 1 inch pipe with a flow rate of 10 gpm had a hammer effect resulting in an increase in pressure of 243 psi above normal operating conditions. Considering normal city water pressure of 50 psi, most end users would select a sensor of approximately 100 psi full scale to be on the safe side. A 100 psi sensor usually has an over pressure of 200% associated with it, meaning it will be able to withstand 200 psi. Now the hammer increases the system from 50 psi to 293 psi (50 + 243), which is overpressurizing the transducer and causing damage to it. Most end users are puzzled as to how a system that is supplied with only 60 psi is capable of producing over 200 psi. After reading this article it should be evident that fluid hammers are a complex phenomena with a simple solution: installing snubbers on all pressure transducers.

PROPERTIES OF WATER AT ATMOSPHERIC PRESSURE

TEMP. °F	DENSITY LBM/FT ³	DENSITY SLUG/FT ³	VISCOSITY LBF-SEC/FT ²	KINEMATIC VISCOSITY FT ² /SEC	SURFACE TENSION LBF/FT	VAPOR PRESSURE HEAD FT	BULK MODULUS LBF/IN ²
32	62.42	1.940	3.746 EE-5	1.931 EE-5	0.518 EE-2	0.20	293 EE3
40	62.43	1.940	3.229 EE-5	1.664 EE-5	0.514 EE-2	0.28	294 EE3
50	62.41	1.940	2.735 EE-5	1.410 EE-5	0.509 EE-2	0.41	305 EE3
60	62.37	1.938	2.359 EE-5	1.217 EE-5	0.504 EE-2	0.59	311 EE3
70	62.30	1.936	2.050 EE-5	1.059 EE-5	0.500 EE-2	0.84	320 EE3
80	62.22	1.934	1.799 EE-5	0.930 EE-5	0.492 EE-2	1.17	322 EE3
90	62.11	1.931	1.595 EE-5	0.826 EE-5	0.486 EE-2	1.61	323 EE3
100	62.00	1.927	1.424 EE-5	0.739 EE-5	0.480 EE-2	2.19	327 EE3
110	61.86	1.923	1.284 EE-5	0.667 EE-5	0.473 EE-2	2.95	331 EE3
120	61.71	1.918	1.168 EE-5	0.609 EE-5	0.465 EE-2	3.91	333 EE3
130	61.55	1.913	1.069 EE-5	0.558 EE-5	0.460 EE-2	5.13	334 EE3
140	61.38	1.908	0.981 EE-5	0.514 EE-5	0.454 EE-2	6.67	330 EE3
150	61.20	1.902	0.905 EE-5	0.476 EE-5	0.447 EE-2	8.58	328 EE3
160	61.00	1.896	0.838 EE-5	0.442 EE-5	0.441 EE-2	10.95	326 EE3
170	60.80	1.890	0.780 EE-5	0.413 EE-5	0.433 EE-2	13.83	322 EE3
180	60.58	1.883	0.726 EE-5	0.385 EE-5	0.426 EE-2	17.33	313 EE3
190	60.36	1.876	0.678 EE-5	0.362 EE-5	0.419 EE-2	21.55	313 EE3
200	60.12	1.868	0.637 EE-5	0.341 EE-5	0.412 EE-2	26.59	308 EE3
212	59.83	1.860	0.593 EE-5	0.319 EE-5	0.404 EE-2	33.90	300 EE3

MOUNTING AND INSTALLING LOAD CELLS

A LOOK AT THE EFFECT OF VARIOUS INSTALLATION CRITERIA

By LaVar Clegg

Most load cell data sheets provide performance information in terms of output, non-linearity, hysteresis, creep, and temperature sensitivity. Such parameters are based on application of ideal or axial loads. In this article we will discuss the response of load cells to non-axial loads and the effects of imperfect mounting conditions.

ANGULAR LOAD

An angular load is one which is applied at the intended point but at an angle with respect to the primary axis. There are at least two ways in which an angular load can originate. First, it can be the result of an axial load plus a side load. Second, it can be caused by a vertical load acting on a beam that is not mounted perfectly level.

An unlevel cell mounting is not an unusual condition in practice. To analyze this condition, refer to Figure 1. The angular load P can be resolved trigonometrically into an axial load as a side load. The load cell, of course, responds to the axial component $P\cos\theta$. Assuming that the response of the cell to the side load is small and well-behaved (such an assumption is a good one), it is apparent that the error resulting from an angular load, as opposed to an axial load, is easily accounted for in a calibration process. There is no contribution to non-linearity; therefore the error is not an error at all as far as measurement accuracy is concerned. This is comforting to know because it would be impractical to do precision leveling on an installation and then maintain it. There is a serious source of measurement error which pertains to angular loading. It is the condition of an inconsistent angle. If the angle varies with respect to load, non-linearity and possibly hysteresis errors will result. They will not be removable by calibration. For example, consider a case in which the load cell mounting has some compliance because it is due to inadequate support. At no load $\theta=0$, at half load $\theta=1^\circ$, and at full load $\theta=2^\circ$. This situation would produce

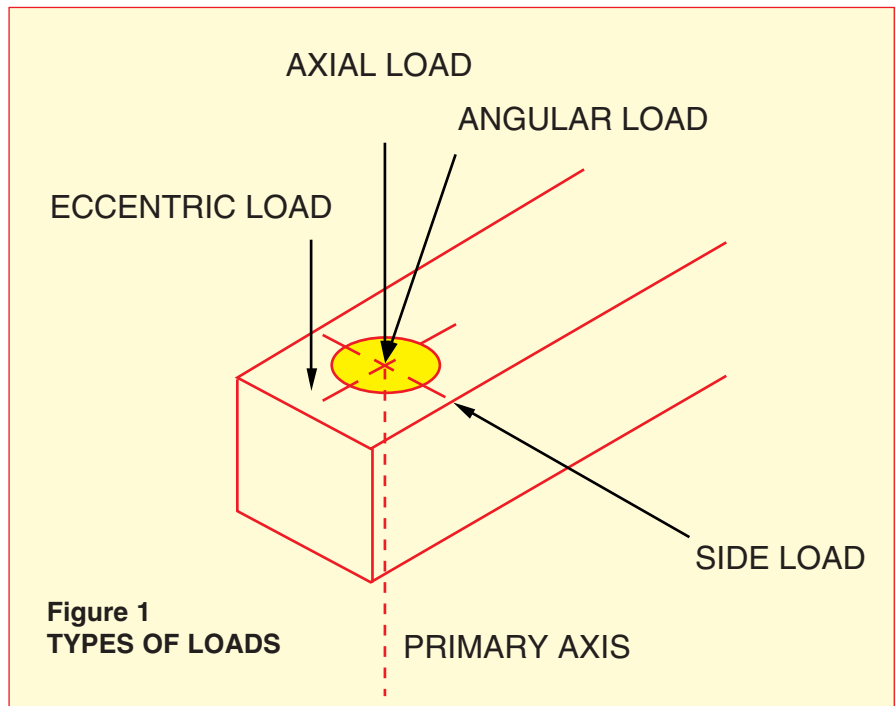

a non-linearity of 0.023% full scale (in addition to any other sources of non-linearity errors) as given by the formula:

$$\%FS = (\cos 1^\circ - \cos 2^\circ)(1/2) = 0.00023$$

ECCENTRIC LOAD

An eccentric load is one that is applied in parallel with the primary axis but not concentric with it. It would be desirable for a cell to respond to an eccentric load with the same sensitivity as to an axial load. Such is not normally the case. However, just as an angular load with constant angle is not a source of error, an eccentric load with constant eccentricity is not a source of error. It is when the load position moves between weighments that a source of error exists.

SIDE LOAD

Any force acting at 90° from the primary axis and on the point of axial load application is called a side load. Side loads are common as they are induced by dynamic loads, expansion and contraction of structures, and various mounting anomalies. Pure side loads are difficult to generate in the laboratory and therefore the response of

load cells to pure side loads is difficult to measure. The response is very low relative to axial load response, and if the test load is not applied at exactly 90° from the primary axis, the small component load in the axial direction will create response overshadowing that of the large side component of the load.

MOUNTING

The preceding information on axial and non-axial loads pertains primarily to the manner of load application to the live end of the beam. Now, let's look at the attachment of the dead end of the beam.

There is no single, correct way to mount single-ended beams. Users seem to learn by experience and skill what works best for their particular application and economic constraints. Nevertheless, good mounting practices are worth enumerating.

Figure 2 illustrates a mounted single-ended beam. It is attached to a foundation on surface A by means of mounting bolts C and D. A load is applied at E. This sketch would be

MOUNTING AND INSTALLING LOAD CELLS *CONTINUED*

used as a reference for some of the aspects of mounting covered below.

1. Surface A should be level in order to minimize non-axial loading. However, modest imperfection in leveling is not a serious source of error so long as the foundation under all loads, from minimum to maximum rated load, is important. The demands on the foundation for stability increase proportionally with increasing load cell capacity. In many installations it is impractical to create structures which remain stable beyond about 10,000 lbs, in which case it is easier to use double-ended load cells.
2. Surface A should be flat. The tensile forces in the mounting bolts C and D should hold the load cell firmly against the foundation.
If these two mating surfaces are not flat, the position taken by the load cell is uncertain. Also, there is the possibility of undesirable bending stresses being induced in the beam, causing non-linearity or hysteresis or both in the load cell output. The mounting surface of load cells is typically flat within 0.002 inch. Surface A should be equally flat.
3. Bolts C and D should be grade 8 or equivalent high-strength bolts. With a load at point E the bolts are in tension. The tendency of such a load is to stretch the bolts and lift the load cell off surface A. Of course, the cell must remain in firm contact with surface A in order to avoid angular load errors. Therefore the bolts must be adequately tightened and only high strength bolts are capable of such tightening.
4. By reasoning of the above point, the mounting bolts should be seated to recommended torque. While the necessary torque is actually determined by the bolt size, the cell capacity, and the cell dimensions, it is convenient to generalize as follows:

BOLT DIA.	TORQUE (FT-LBS)
1/4 in	12
1/2 in	100
3/4 in	350

5. Because stretching of the mounting bolts is undesirable, short bolts are recommended. The threads in the foundation should begin at surface A. Recessed threads or a large spacer between the cell and foundation which cause the distance between bolt heads and foundation threads to exceed the load cell thickness should be avoided.
6. Washers under the bolt heads are optional. If they are used, they should be hardened, grade 8, or equivalent. Lock washers or flat washers are permissible.

7. With high capacity cells starting at about the 5000-lb range, point B beings to show deformation under repeated loading. In such cases it is recommended that the foundation be hardened steel. The body of high capacity single-ended beams is typically relatively hard, about Rockwell C-45, so a slightly lower hardness than that would be appropriate for a foundation.

By understanding the possible sources of error and by using good mounting practices, loading conditions can be managed to contribute negligible effect on weighing accuracy in practical installations.

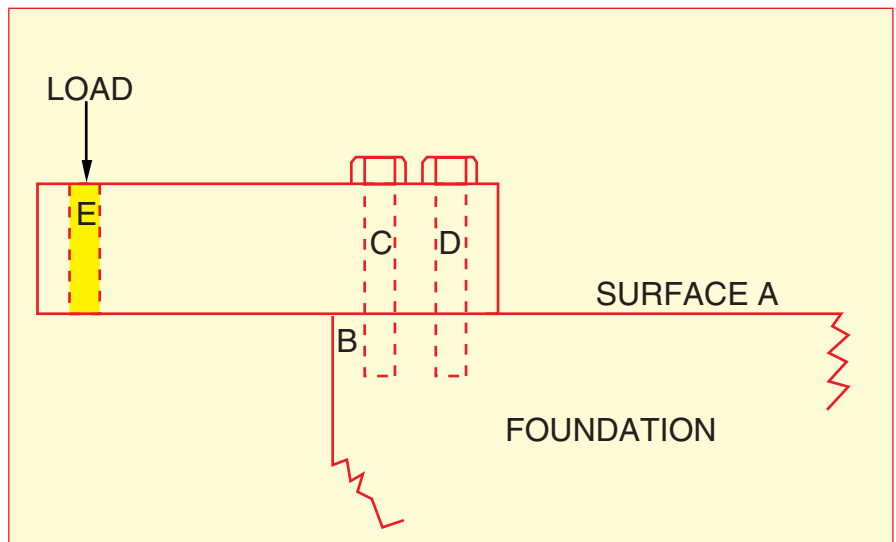

Figure 2: Simple Mounting Diagram